



410 SS Stealth-Series Air Compressor

200 PSI / 1.73 CFM

Max. Amp Draw: 25 Amps

P/N 41040 - 12V



The 410 Stealth-Series (SS) compressor/s feature upgraded internals, a proprietary developed head and a new metal filter assembly with internally integrated muffler, reducing audible noise levels by up to 50% when compared to our other comparable compressors*. Additionally, the 410 Stealth-Series compressors are RoHS/REACH certified and equipped with newly designed spring-loaded vibration isolators, black sleeved stainless steel leader hose and black nickel-plated check valves that eliminate the possibility of high amperage restarts.

Note: Use thread sealant for proper installation. Thread tape is not recommended. Properly sealed, recommended torque for 1/8" is 10 ~ 11 ft. lbs. Recommended torque for 1/4" and 3/8" is 16 ~ 18 ft. lbs.

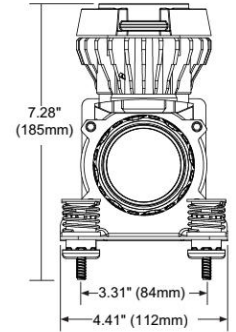
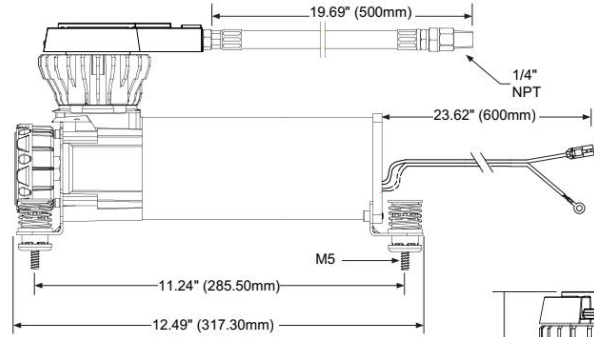

*Compared to VIAIR 444C/480C compressors noise levels.

Please contact your representative for pricing.

Included Parts:

- Thermal Overload Protector
- Check Valve
- Spring Loaded Vibration Isolating Feet
- Mounting Hardware
- Stainless Steel Braided Leader Hose
- Air Line for Remote Mount Air Filter
- Remote Mount 6-Stage Air Filter/Muffler Assembly
- (2) Replacement Air Filter Elements
- Installation Instructions

Specifications:

- 12-Volt
- Permanent Magnetic Motor
- Duty Cycle: 100% @ 100 PSI
- Duty Cycle: 50% @ 200 PSI
- Max. Working Pressure: 200 PSI
- Max. Air Tank Size: 5.0 Gallon
- Max. 12V Amp Draw: 25-Amps
- Ingress Protection Rating: IP67
- Dimensions: 12.5" L x 4.4" W x 7.3" H
- Net Weight: 9.75 lbs.

Performance Data					
PSI	CFM	A	BAR	LPM	A
0	1.73	15	0	49	15
20	1.34	17	2	37	17
40	1.27	18	4	33	19
60	1.13	19	6	29	20
80	1.06	20	8	26	21
100	0.99	21	10	23	21
120	0.92	21	12	21	21
140	0.85	21	14	18	21

Recommended Components:

- 2.5 Gallon Tank - P/N 91028
- 5.0 Gallon Tank - P/N 91050
- 12V Relay - P/N 93940, 93944;
- Pressure Switches - All Pressure Switches

Tank Fill Rates	
2.5 GALLON TANK	FILL RATE
0 to 145 PSI	3 min. 15 sec. (± 15 sec.)
110 to 145 PSI	1 min. 10 sec. (± 10 sec.)
0 to 200 PSI	4 min. 55 sec. (± 15 sec.)
165 to 200 PSI	1 min. 10 sec. (± 10 sec.)
5.0 GALLON TANK	FILL RATE
0 to 145 PSI	6 min. 30 sec. (± 20 sec.)
110 to 145 PSI	1 min. 50 sec. (± 10 sec.)
0 to 200 PSI	10 min. 10 sec. (± 20 sec.)

Applications include:

