



325C Compressor

150 PSI / 1.59 CFM 12V / 1.80 CFM 24V

12V Max. Amp Draw: 22 Amps

24V Max. Amp Draw: 13 Amps

P/N 32530 - 12V - Silver €€

P/N 32533 - 12V - Chrome €€

P/N 32538 - 24V - Silver €€

P/N 32534 - 12V - Silver, No Leader Hose or Check Valve €€



Your Vital Air Source

The 325C air compressor is used in a variety of applications from industrial to motorsports. It has a max run time of 20 minutes and comes in 4 different configurations to fit the needs of every customer.

Note: Use thread sealant for proper installation. Teflon tape is not recommended. Properly sealed, recommended torque is 12 to 15 ft. lbs.



P/N 32530, 32533, 32538

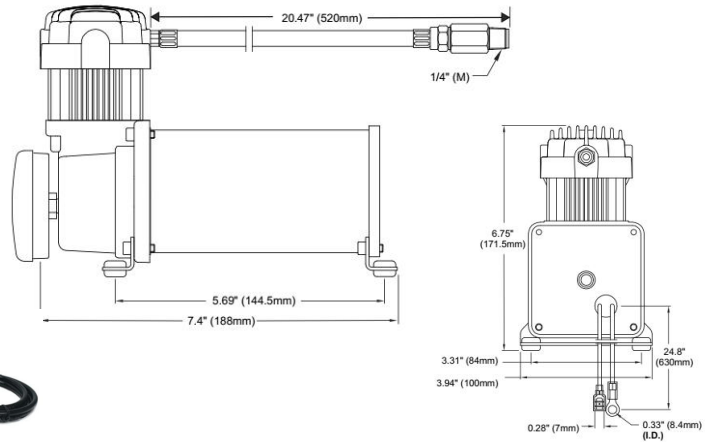

P/N 32534

Please contact your representative for pricing.

Included Parts:

- Thermal Overload Protector
- Check Valve
- Mounting Hardware
- Vibration Isolators
- Stainless Steel Braided Leader Hose
- Air Line for Remote Mount Air Filter
- Remote Mount Air Filter Assembly
- (2) Replacement Air Filter Elements
- Installation Instructions

Recommended Components:

- 2.5 Gallon Tank - P/N 91028,
- 5.0 Gallon Tank - P/N 91050;
- 12V Relay - P/N 93940;
- 24V Relay - P/N 93943;
- Pressure Switches - P/N 90100, 90102;
- Pressure Switches with Relay - P/N 90110, 90111
- Sealed Pressure Switch - P/N 90217, 90223, 90227
- Leader Hose with Check Valve - P/N 92793

Specifications:

- 12-Volt or 24-Volt
- Permanent Magnetic Motor
- Duty Cycle: 33% @ 100 PSI
- Max. Working Pressure: 150 PSI
- Max. Air Tank Size: 5.0 Gallon
- Max. 12V Amp Draw: 22-Amps
- Max. 24V Amp Draw: 13-Amps
- 1/4" NPT Intake Port
- Ingress Protection Rating: IP67
- Max Ambient Temp: +158°F
- Min Ambient Temp: -40°F
- Dimensions: 8" L x 4" W x 6.75" H
- Net Weight: 7.5 lbs.

Performance Data					
12-VOLT COMPRESSOR - Supply Voltage 13.8 Volts					
PSI	CFM	A	BAR	LPM	A
0	1.59	14	0	45	14
20	1.24	16	2	34.1	18
40	1.17	18	4	29.1	20
60	1.01	20	6	23.7	21
80	0.87	21	8	19.7	21
100	0.77	21	10	16.5	21

Performance Data					
24-VOLT COMPRESSOR - Supply Voltage 28 Volts					
PSI	CFM	A	BAR	LPM	A
0	1.8	7	0	51	7
20	1.41	9	2	38.7	10
40	1.31	10	4	34.3	11
60	1.2	11	6	30	11
80	1.09	11	8	26.4	13
100	0.99	12	10	22.5	12

Tank Fill Rates		
2.5 GALLON TANK	12-Volt	24-Volt
0 to 105 PSI	2 min. 35 sec. (± 10 sec.)	2 min. 25 sec. (± 10 sec.)
85 to 105 PSI	40 sec. (± 05 sec.)	35 sec. (± 05 sec.)
0 to 145 PSI	4 min. 15 sec. (± 10 sec.)	3 min. 30 sec. (± 10 sec.)
110 to 145 PSI	1 min. 25 sec. (± 05 sec.)	1 min. 10 sec. (± 05 sec.)
5.0 GALLON TANK	12-Volt	24-Volt
0 to 105 PSI	5 min. 15 sec. (± 10 sec.)	4 min. 45 sec. (± 10 sec.)
85 to 105 PSI	1 min. 25 sec. (± 05 sec.)	1 min. 05 sec. (± 05 sec.)
0 to 145 PSI	8 min. 45 sec. (± 15 sec.)	7 min. 25 sec. (± 15 sec.)
110 to 145 PSI	2 min. 55 sec. (± 10 sec.)	2 min. 25 sec. (± 10 sec.)

Applications include:

