

450C-IG Compressor

150 PSI / 1.80 CFM 12V / 2.20 CFM 24V

12V Max. Amp Draw: 23 Amps

24V Max. Amp Draw: 13 Amps

P/N 45050 - 12V €€

P/N 45058 - 24V €€



Your Vital Air Source



The 450 IG air compressors are heavy-duty, 150 PSI industrial units designed to fill air tanks and feature a head assembly designed for better heat dissipation. They're equipped with a separate stainless steel braided PTFE-lined leader hose and check valve assembly that protects the compressor against high amperage restarts. Available in 12V or 24V.

Please Note: Use thread sealant for proper installation. Thread tape is not recommended.

Properly sealed, recommended torque for 1/8" is 10 ~ 11 ft. lbs. Recommended torque for 1/4" and 3/8" is 16 ~ 18 ft. lbs.

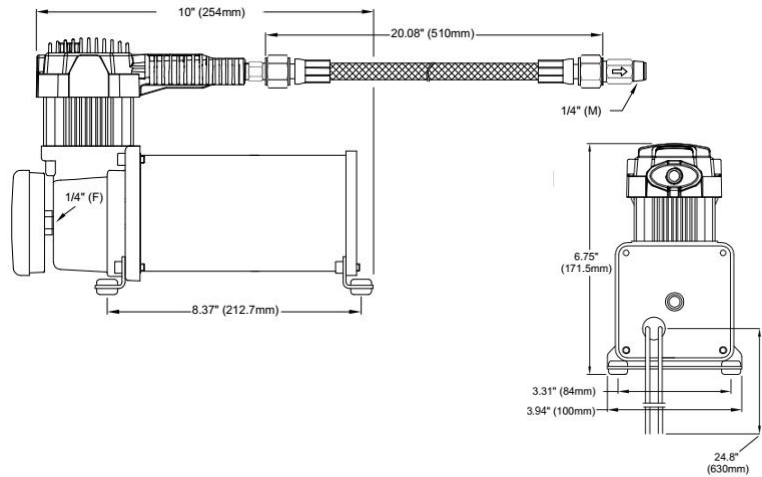

Please contact your representative for pricing.

Included Parts:

- Thermal Overload Protector
- Vibration Isolators
- Mounting Hardware
- Heavy Duty 1/4" NPT Check Valve
- Stainless Steel Braided PTFE-lined Leader Hose
- Air Line for Remote Mount Air Filter
- Remote Mount Air Filter Assembly
- (2) Replacement Air Filter Elements
- Installation Instructions

Specifications:

- 12-Volt or 24-Volt
- Permanent Magnetic Motor
- Duty Cycle: 100% @ 100 PSI
- Max. Working Pressure: 150 PSI
- Max. Air Tank: 5.0 Gallon
- Max. 12V Amp Draw: 23-Amps
- Max. 24V Amp Draw: 13-Amps
- Ingress Protection Rating: IP67
- Max. Ambient Temp: +158°F
- Min. Ambient Temp: -40°F
- Dimensions: 11.25" L x 4" W x 6.75" H
- Net Weight: 10.40 lbs.

Recommended Components:

- 0.5 Gallon Tank - P/N 91005;
- 1.0 Gallon Tank - P/N 91010; 91014
- 2.0 Gallon Tank - P/N 91022;
- 2.5 Gallon Tank - P/N 91025;
- 5.0 Gallon Tank - P/N 91050;
- 12V Relay - P/N 93940, 93977, 93980;
- 24V Relay - P/N 93943, 93979;
- Pressure Switches - P/N 90100, 90101, 90102;
- Pressure Switches with Relay - P/N 90110*, 90111*, 90113*;
- Sealed Pressure Switch - P/N 90217, 90223, 90227, 90212;

Performance Data						
12-VOLT COMPRESSOR - Supply Voltage 13.8 Volts						
PSI	CFM	A	BAR	LPM	A	
0	1.8	12	0	51	12	
20	1.6	16	2	43.3	17	
40	1.39	18	4	34	19	
60	1.18	19	6	28.1	21	
80	1.04	20	8	25	23	
100	0.9	22	10	21	21	

Performance Data						
24-VOLT COMPRESSOR - Supply Voltage 28 Volts						
PSI	CFM	A	BAR	LPM	A	
0	2.2	8	0	62.3	8	
20	1.86	11	2	50.6	11	
40	1.69	11	4	43.4	12	
60	1.52	12	6	37.7	12	
80	1.38	12	8	32	12	
100	1.24	13	10	26	12	

Tank Fill Rates		
2.5 GALLON TANK	12-Volt	24-Volt
0 to 105 PSI	1 min. 55 sec. (± 10 sec.)	1 min. 45 sec. (± 10 sec.)
85 to 105 PSI	28 sec. (± 05 sec.)	25 sec. (± 05 sec.)
0 to 145 PSI	3 min. 02 sec. (± 10 sec.)	2 min. 40 sec. (± 10 sec.)
110 to 145 PSI	59 sec. (± 05 sec.)	50 sec. (± 05 sec.)
5.0 GALLON TANK	12-Volt	24-Volt
0 to 105 PSI	4 min. 00 sec. (± 10 sec.)	3 min. 20 sec. (± 10 sec.)
85 to 105 PSI	58 sec. (± 05 sec.)	50 sec. (± 05 sec.)
0 to 145 PSI	6 min. 25 sec. (± 15 sec.)	5 min. 15 sec. (± 15 sec.)
110 to 145 PSI	2 min. 11 sec. (± 10 sec.)	1 min. 45 sec. (± 10 sec.)

* For 12V Only.



Applications include:

