

# **VIAR**<sup>®</sup>

*Your Vital Air Source*

## **EVC84P DIGITAL PORTABLE AIR COMPRESSOR**

PART NO. EVC84P

### **USER MANUAL**

## **EVERY VEHICLE CARRY**<sup>®</sup>

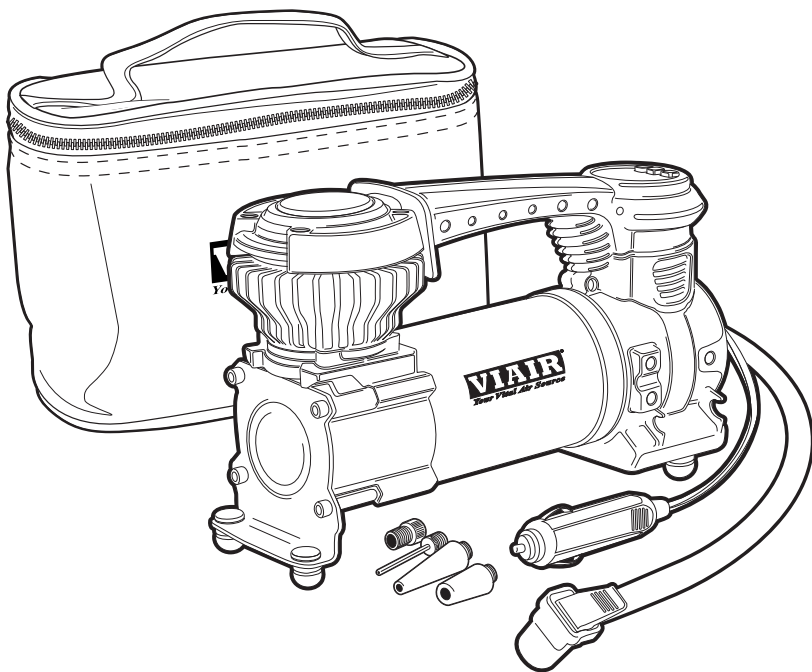

#### **IMPORTANT:**

It is essential that you and any other operator of this product read and understand the contents of this manual before installing and using this product.

**SAVE THIS MANUAL FOR FUTURE REFERENCE**



## EVC84P DIGITAL PORTABLE COMPRESSOR

This is a 12V DC portable air compressor designed to be powered from your vehicle's auxiliary power port (cigarette plug). It can be used for inflating tires, sports balls, and other inflatable equipment. **The engine MUST be running while using this compressor.**

### AMP DRAW WARNING:

Most vehicle's cigarette lighter power ports are rated to support 15-Amps; however, some vehicles may have a lower rating. Check the limitations of your vehicle's power port before operating this compressor. **NEVER attempt to install fuses rated beyond the original capacity of the circuit.**

### IMPORTANT SAFETY INSTRUCTIONS:

1. Do not attempt to disassemble, repair, or modify this unit.
2. Never allow children to operate this compressor.
3. Do not touch any parts other than the ON/OFF switch and carry handle with bare hands. This compressor becomes HOT during and immediately after use.
4. Use in dry, well-ventilated environments only. Protect the unit from rain, snow, and other sources of heavy moisture.
5. Do not leave the compressor running unattended.
6. Do not pump anything other than atmospheric air.
7. Do not operate the compressor near fire, flammable gas or liquid.
8. Never carry the compressor by the hose or power cord.
9. Never point the air nozzle towards another person or any part of the body.
10. Be sure the unit's power switch is in the OFF position when not in use.

### PRODUCT OVERVIEW:

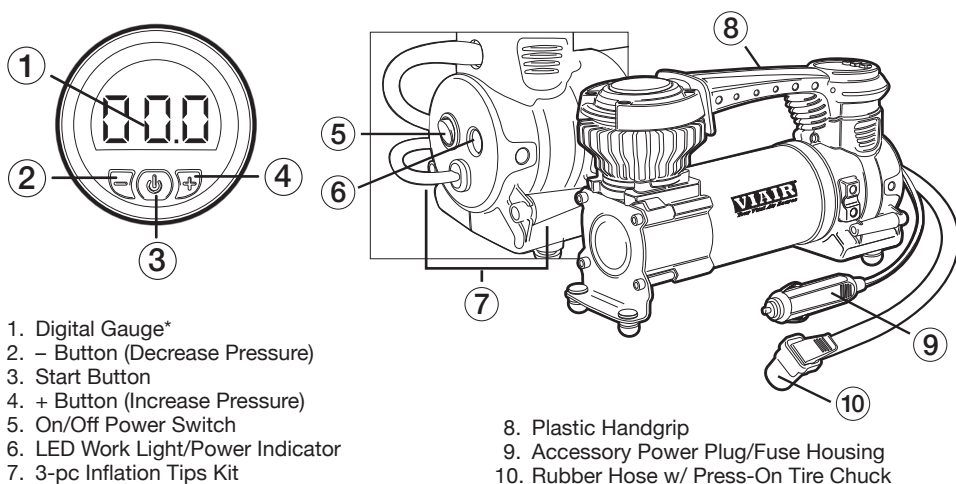

1. Digital Gauge\*
2. - Button (Decrease Pressure)
3. Start Button
4. + Button (Increase Pressure)
5. On/Off Power Switch
6. LED Work Light/Power Indicator
7. 3-pc Inflation Tips Kit

8. Plastic Handgrip
9. Accessory Power Plug/Fuse Housing
10. Rubber Hose w/ Press-On Tire Chuck

### FEATURES:

1. Preset Pressure w/ Auto Shut-Off
2. Easy to Read Digital Gauge\*
3. LED Work Light/ Power Indicator
4. Accessory Power Plug/ Fuse Housing
5. 3-pc Inflation Tips Kit w/ Presta Valve Adapter
6. Deluxe Carry Bag

\* Accuracy: +/- 1 PSI

# EVC84P DIGITAL PORTABLE COMPRESSOR

## OPERATING INSTRUCTIONS:

---

**IMPORTANT: Engine MUST be running while using this compressor.**

### BEFORE USE:



- Make sure the power switch is in the OFF position before connecting to the power source.
- Make sure the power cord is uncoiled and fully extended to avoid overheating.

### USING THE COMPRESSOR:

1. Plug the compressor to an accessory power port.
2. **Turn the vehicle engine on**
3. Attach the Press-On air chuck to the valve stem.
4. Turn the power switch to ON ( I ), the gauge will illuminate.
5. Press the (+) and (-) buttons simultaneously to select the desired pressure unit (PSI, BAR, KPA or Kg/cm2).
6. Use the (+) and (-) buttons to select the desired inflation pressure.
7. Press the Start Button ON , the compressor will begin to inflate and automatically shut off at the desired pressure.
8. Turn the power switch OFF.
9. Remove air hose from the valve stem and unplug the compressor.

**CAUTION: To avoid bursting, never exceed recommended inflation pressures.**

**IMPORTANT: DO NOT rely on the Auto Shut-Off function for anything other than tires. For all other inflatable objects such as sports balls, toys, and floatable items:**

1. Simply screw the appropriate nozzle provided in the Inflation Tips Kit to the tip of the air hose.
2. Attach the nozzle to the object and Press the Start Button .
3. When desired firmness is achieved, Press the Start Button .

**WARNING: Your Portable Air Compressor is Moisture and Dust Resistant, but NOT WATER OR DUST PROOF. Never operate a compressor in soft sand or dirt. Vibration will cause the unit to settle into the soft surface and draw foreign particles, causing internal damage. Never expose the compressor to water during operation.**

### MAINTENANCE:

Your compressor is equipped with a permanently lubricated, maintenance-free motor. Never try to lubricate the compressor. Use a clean, damp cloth with mild soap to clean the body. All other maintenance should be performed by a qualified technician.

## MODEL EVC84P SPECIFICATIONS:

---

Part Number:	EVC84P
Voltage:	12V DC
Ingress Protection Rating:	IP53
Max. Amp Draw:	15-Amps / 180-Watts
Aux. Plug Fuse:	15A
Max. Working Pressure:	100 PSI*
Max. Duty Cycle (@ 72°F):	20min @ 30 PSI
Flow Rate @ 0 PSI (13.8 Volts):	1.77 CFM
Ambient Temperature:	-4°F ~ +158°F
Dimensions:	9.10" (L) x 3.10" (W) x 5.60" (H)
Power Cord Length:	10 ft.
Air Hose Length:	3 ft.
Weight:	4.30 Lbs. / 1.95 Kgs

\* Do not exceed compressor's max working pressure to prevent damage to the compressor.

# EVC84P DIGITAL PORTABLE COMPRESSOR

## TROUBLESHOOTING GUIDE:

PROBLEM:	POSSIBLE CAUSE(S)	CORRECTIVE ACTION
Compressor does not turn on	1. No power, or switch in off position 2. Blown fuse.	1. Make sure compressor switch is on. 2. Disconnect compressor from power source, replace fuse (refer to specifications section for correct fuse)
Excessive knocking or rattling	1. Worn Bearing on eccentric or motor shaft. 2. Cylinder or piston ring is worn	1. Replace Compressor 2. Replace Compressor
Low or no air flow Compressor cannot pump to higher pressure	1. Worn piston ring 2. Damaged reed valve	1. Replace Compressor 2. Replace Compressor

### LIMITED WARRANTY:

VIAIR® Corporation warrants this product, when properly installed and under normal conditions of use, to be free from defects in workmanship and materials for a period of one year from its original date of purchase. To receive warranty service or repair, please contact VIAIR® Corporation.

Returns should be made within one year of the date of purchase, after a Return Goods Authorization (RGA) number has been assigned by VIAIR® Corporation. To obtain RGA, fax a copy of your receipt to (949) 585-0188. For complete warranty details, please visit: [www.viaircorp.com/warranty](http://www.viaircorp.com/warranty)

### PLEASE NOTE:

THIS WARRANTY COVERS PRODUCT DEFECTS ONLY; IT DOES NOT COVER INCIDENTAL OR CONSEQUENTIAL DAMAGES AS RESULT OF MISUSE OR ABUSE.

This Manual is proprietary to VIAIR® Corporation and no ownership rights are hereby transferred. No part of the Manual shall be used, reproduced, translated, converted, adapted, stored in a retrieval system, communicated or transmitted by any means, for any commercial purpose, including without limitation, sale, resale, license, rental or lease, without the prior express written consent of VIAIR®. VIAIR® does not make any representations, warranties or guarantees, express or implied, as to the accuracy or completeness of the Manual. Users must be aware that updates and amendments will be made from time to time to the Manual. It is the user's responsibility to determine whether there have been any such updates or amendments. Neither VIAIR® nor any of its directors, officers, employees or agents shall be liable in contract, tort or in any other manner whatsoever to any person for any loss, damage, injury, liability, cost or expense of any nature, including without limitation incidental, special, direct or consequential damages arising out of or in connection with the use of the Manual.



15 EDELMAN • IRVINE, CA 92618  
TEL: (949) 585-0011 • FAX: (949) 585-0188  
[www.viaircorp.com](http://www.viaircorp.com)