

**VIAIR**<sup>®</sup>

*Your Vital Air Source*

**VMS**  
VIAIR MOUNTED SYSTEM



## DUAL 444 EF HIGH PERFORMANCE COMPRESSOR

PN: 444DB-EF (Stealth Black) / PN: 444DC-EF (Chrome)

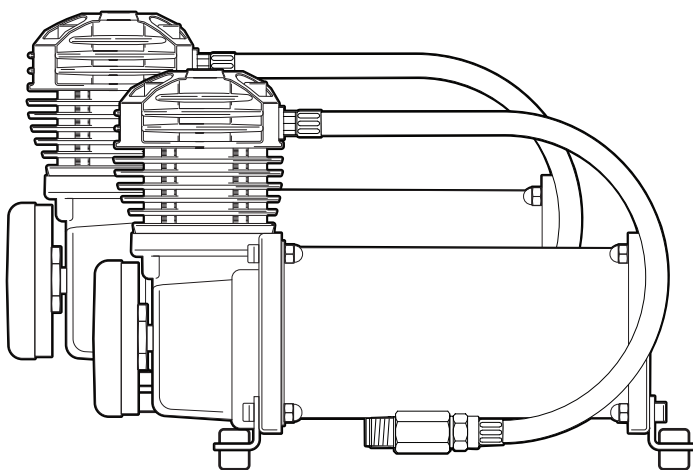

### IMPORTANT:

It is essential that you and any other operator of this product read and understand the contents of this manual before installing and using this product.

**SAVE THIS MANUAL FOR FUTURE REFERENCE**

**USER MANUAL**



# DUAL 444 EF HIGH PERFORMANCE COMPRESSORS

## IMPORTANT SAFETY INSTRUCTIONS

---

### **CAUTION** - To reduce risk of electrical shock:

- Do not disassemble. Do not attempt repairs or modifications. Refer to qualified service agencies for all service and repairs.
- Do not use this product in an area where it can fall or be pulled into water or other liquids.
- Do not reach for this product if it has fallen into liquid.
- Use compressors with 12-Volt DC systems only.
- This product should never be left unattended during use.

### **WARNING** - To prevent injury:

- Never allow children to operate compressors. Close supervision is necessary when this compressor is being used near children.
- Compressors will become very HOT during and immediately after use. Do not touch any part of them with bare hands during and immediately after use.
- Do not use this product near flames or explosive materials or where aerosol products are being used.
- Do not operate this product where oxygen is being administered.
- Do not pump anything other than atmospheric air.
- Never use this product while sleepy or drowsy.
- Do not use any tools or attachments without first determining maximum air pressure for that tool or attachment.
- Never point any air nozzle or air sprayer toward another person or any part of the body.
- Each 400C air compressor is equipped with an Automatic Reset Thermal Protector, and can automatically restart after the thermal protector resets. Always cut off power source when thermal protector becomes activated.
- Wear safety glasses or goggles when installing this product.
- Use only in well ventilated areas.

## INSTALLATION

---

Please read and follow the installation instructions carefully to avoid injury or damage to the compressor and your vehicle.

Each of our air compressors and parts have been carefully produced and packaged. Before you begin installation, please familiarize yourself with Installation Parts List (Fig. 1) of this manual.

### Guidelines for Selecting Mounting Location:

The selection of proper mounting location for your air compressor will help ensure a long and trouble free compressor service life. Please pay close attention to the following guidelines:

1. Select a FLAT AND SECURE location where the compressors can be mounted.
2. To maximize air compressor performance, locate compressor as CLOSE TO THE BATTERY as possible so that the length of positive lead wire required is at a minimum.
3. Choose mounting location that is as cool as possible and AWAY FROM HEAT SOURCES. The cooler the ambient temperature the less chance the compressor will overheat.
4. These compressors are moisture & splash resistant, but NOT WATERPROOF. Do not mount compressor in locations where the unit is likely to come in contact with water.
5. For remote filter mounting (sold separately), select compressor mounting location where air line can be routed from compressor air inlet to remote inlet air filter. Make sure Remote Inlet Air Filter is located in a dry location, away from the elements.
6. If it is necessary to mount air compressors further away from the battery, such as inside your vehicle or on the chassis of a pickup, use a minimum 6 AWG positive lead wire.
7. Do not mount compressor near areas where flammable liquids are stored.

## DUAL 444 EF HIGH PERFORMANCE COMPRESSORS

### MOUNTING AND WIRING

1. Disconnect ground cable from vehicle's battery.
2. Temporarily position the air compressor in the location where it will be mounted.
3. Route ground wire to the negative post of the battery or to an appropriate grounding point and cut ground wire to length as needed.
4. Mount each air compressor with the hardware provided (See Fig. 2 for assembly diagram)
5. Your air compressors come with heavy duty heat-resistant leader hose with 1/4" fittings. This leader hose is designed to prolong the life of your air line. Do not remove the leader hoses from the air compressors.
6. **IMPORTANT:** Please note, the leader hose that came with your compressor may have a built-in inline check valve. Do not remove inline check valve from leader hose.
7. Connect compressor positive lead wire to one of the leads of your pressure switch (sold separately).
8. Make sure that your compressor setup is properly fused. Both compressors will pull no more than 60-Amps (DUAL 444C) peak.
9. Always locate fuse as close as possible to power source.
10. Before connecting to power source, re-check to make sure that all connections are made properly.
11. Connect and test compressor system by running the compressor for a short time to build up pressure in your air tank.
12. Once air pressure reaches preset cut out pressure of your pressure switch, the compressor will shut off. Inspect all air line connections for leaks with soap and water solution. If a leak is detected, the air line may not be cut squarely or pushed all the way in. Repair connections as needed.

#### (Fig. 1) 400 EF High Performance Compressor Component List:

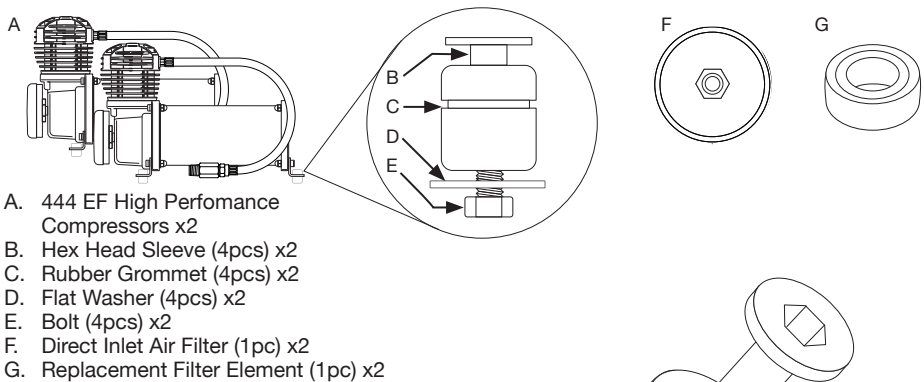

#### (Fig. 2) Mounting Hardware Assembly Diagram:

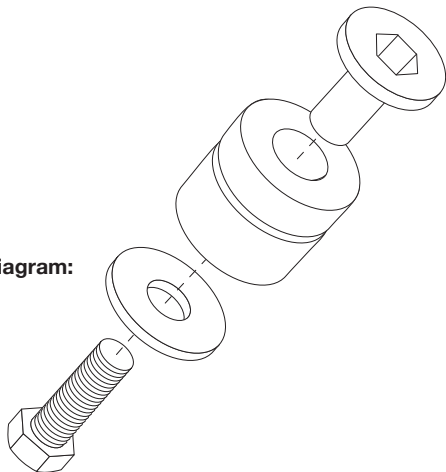

# DUAL 444 EF HIGH PERFORMANCE COMPRESSORS

## OPERATING INSTRUCTIONS

---

1. **IMPORTANT:** Always operate the compressors at or below the **MAXIMUM PRESSURE RATING** of the compressor (150 PSI).
2. Always observe the **MAXIMUM DUTY CYCLE** of the air compressor. Refer to Compressor Applications and Specifications Sections of this manual for details. Operation exceeding maximum pressure ratings and/or duty cycle will result in damage to the air compressor.
3. Your air compressors are equipped with **AUTOMATIC THERMAL OVERLOAD PROTECTORS**. This feature is designed to protect the air compressor from overheating and causing permanent damage. The thermal overload protector will automatically cut power to your air compressor should the internal operating temperature of the air compressor rise above safe levels during excessive use.
4. Should at any time during use, your air compressors automatically shut off, do not attempt to restart them. Cut power to the air compressor. The automatic thermal overload protector will automatically reset when internal temperature of the air compressor drops below safe levels. After allowing air compressor to cool off for about 30 minutes, you can safely resume use of the air compressor.
5. To prevent discharge of your vehicle's battery, we recommend that you keep the vehicle's engine running while operating air compressors.
6. **ONLY OPERATE AIR COMPRESSORS IN WELL-VENTILATED AREAS.**
7. Compressor performance is enhanced when operating compressor with vehicle's engine running.
8. **INSTALLATION TIP:**  
Always plumb your system using a separate tank port for each compressor leader hose. This can improve flow performance.

## MAINTENANCE & REPAIRS

---

1. Periodically check all electrical, fittings connections. Clean and tighten as needed.
2. Periodically check all mounting screws. Tighten as needed.
3. Replace Air Filter Element periodically. Replacement frequency depends on operating frequency and operating environment. For frequent use in dusty environments, we recommend that you replace air filter element once a month.
4. Regularly clean dust and dirt from compressor cooling fins and motor housing.
5. Your air compressor is equipped with a permanently lubricated, maintenance-free motor. Never try to lubricate the compressor.
6. All repairs should be performed by Manufacturer or Manufacturer's Authorized Service Agencies only.

### **CAUTION:**

Never touch the air compressor or fittings connected to the air compressor with bare hands during or immediately after use. The leader hose and fittings connected to leader hose will become very **HOT** during and after use. If necessary, wear heat resistant gloves to handle fittings, air line, and leader hose.

# DUAL 444 EF HIGH PERFORMANCE COMPRESSORS

## COMPRESSOR APPLICATION GUIDE

---

To ensure that you get the highest level of satisfaction from your compressor's performance, refer to information below:

### VIAIR® COMPRESSOR REFERENCE CHART

COMPRESSOR SERIES	MAX. WORKING PRESSURE	DUTY CYCLE (100 PSI @ 72°F)
090 SERIES	120 PSI	9%
092 SERIES	120 PSI	9%
095 SERIES	120 PSI	9%
097 SERIES	130 PSI	10%
098 SERIES	130 PSI	10%
100 SERIES	130 PSI	15%
250 IG SERIES	150 PSI	100%
275 SERIES	150 PSI	25%
280 SERIES	150 PSI	30%
310 SERIES	200 PSI	100%
		55% @ 200 PSI
325 SERIES	150 PSI	33%
330 IG SERIES	150 PSI	100%
350 SERIES	150 PSI	100%
380 SERIES	200 PSI	100%
		55% @ 200 PSI
400 SERIES	150 PSI	33%
420 SERIES	150 PSI	33%
425 SERIES	175 PSI	33% @ 175 PSI
		50%
444 SERIES	200 PSI	100%
		50% @ 200 PSI
450 SERIES	150 PSI	100%
450 IG SERIES	150 PSI	100%
460 SERIES	150 PSI	100%
480 SERIES	200 PSI	100%
		50% @ 200 PSI
485 SERIES	200 PSI	100%
		100% @ 200 PSI

### ABOUT COMPRESSOR DUTY CYCLE:

Duty cycle refers to the amount of time a compressor can be operated in a given time period at 100 PSI, and a standard ambient temperature of 72° F. It is commonly expressed in percentage format: Compressor on time ÷ (on time + off time) = Duty Cycle%.

### ONE-HOUR DUTY CYCLE

(100 PSI @ 72°F)

9%  
10%  
15%  
20%  
25%  
30%  
33%  
50%  
100%

### MINUTES ON / MINUTES OFF

5 Min. On / 55 Min. Off  
6 Min. On / 54 Min. Off  
9 Min. On / 51 Min. Off  
12 Min. On / 48 Min. Off  
15 Min. On / 45 Min. Off  
18 Min. On / 42 Min. Off  
20 Min. On / 40 Min. Off  
30 Min. On / 30 Min. Off  
1 Hour Run Time

**NOTE:** All compressors, regardless of rated duty cycle, require sufficient rest time in between cycles to allow for partial or complete heat dissipation. Heat dissipation rates may vary depending on ambient temperatures and operating conditions.

### ABOUT RATED WORKING PRESSURE:

To ensure trouble free service life of your compressor, always operate compressor within rated working pressure of the compressor. Never use a pressure switch with a higher cut-off pressure than compressor's rated working pressure.

## DUAL 444 EF HIGH PERFORMANCE COMPRESSORS

### TROUBLESHOOTING GUIDE:

PROBLEM	POSSIBLE CAUSE(S)	CORRECTIVE ACTION
Tank pressure drops when compressor(s) shut off	<ol style="list-style-type: none"> <li>1. Loose drain cock</li> <li>2. Check valve leaking</li> <li>3. Loose connections</li> </ol>	<ol style="list-style-type: none"> <li>1. Tighten drain cock</li> <li>2. Replace check valve or compressor(s)</li> <li>3. Check all connections with soap and water solution and tighten</li> </ol>
Compressor runs continuously and air flow lower than normal	<ol style="list-style-type: none"> <li>1. Excessive air usage</li> <li>2. Loose connections</li> <li>3. Worn piston ring or inlet valve.</li> <li>4. Clogged air filter element</li> </ol>	<ol style="list-style-type: none"> <li>1. Decrease air usage</li> <li>2. Check all connections with soap and water solution and tighten.</li> <li>3. Repair or replace compressor</li> <li>4. Replace air filter element</li> </ol>
Compressor runs continuously causing safety valve (if equipped) to open	<ol style="list-style-type: none"> <li>1. Bad pressure switch</li> <li>2. Defective safety valve</li> </ol>	<ol style="list-style-type: none"> <li>1. Replace pressure switch</li> <li>2. Replace safety valve</li> </ol>
Excessive moisture in discharge	<ol style="list-style-type: none"> <li>1. Excessive water in air tank</li> <li>2. High humidity</li> </ol>	<ol style="list-style-type: none"> <li>1. Drain tank, tilt tank to drain. Drain tank more frequently</li> <li>2. Move compressor to area with less humidity, or use air line filter.</li> </ol>
Compressor will not run	<ol style="list-style-type: none"> <li>1. No power, or power switch in OFF position</li> <li>2. Blown fuse</li> <li>3. Motor overheats</li> <li>4. Faulty pressure switch.</li> </ol>	<ol style="list-style-type: none"> <li>1. Make sure compressor switch is ON</li> <li>2. Disconnect compressors from power source, replace fuse. (Refer to Specifications section for correct fuse-Amperage.)</li> <li>3. Let compressors cool off for about 30 minutes to allow thermal overload switch reset.</li> <li>4. Replace pressure switch</li> </ol>
Thermal overload protector cuts out repeatedly	<ol style="list-style-type: none"> <li>1. Lack of proper ventilation or ambient temperature too high</li> <li>2. Compressor valves failed</li> </ol>	<ol style="list-style-type: none"> <li>1. Move compressor to well ventilated area, or area with lower ambient temperature</li> <li>2. Repair or replace compressor</li> </ol>
Excessive knocking or rattling	<ol style="list-style-type: none"> <li>1. Loose mounting bolts</li> <li>2. Worn bearing on eccentric or motor shaft</li> <li>3. Cylinder or piston ring is worn</li> </ol>	<ol style="list-style-type: none"> <li>1. Tighten mounting bolts</li> <li>2. Repair or replace compressor</li> <li>3. Repair or replace compressor</li> </ol>

**CAUTION: NEVER DISASSEMBLE COMPRESSOR WHILE COMPRESSOR IS PRESSURIZED.**

# DUAL 444 EF HIGH PERFORMANCE COMPRESSORS

## Wiring Diagram:

(Pressure Switch, Relays & Fuse Not Included)

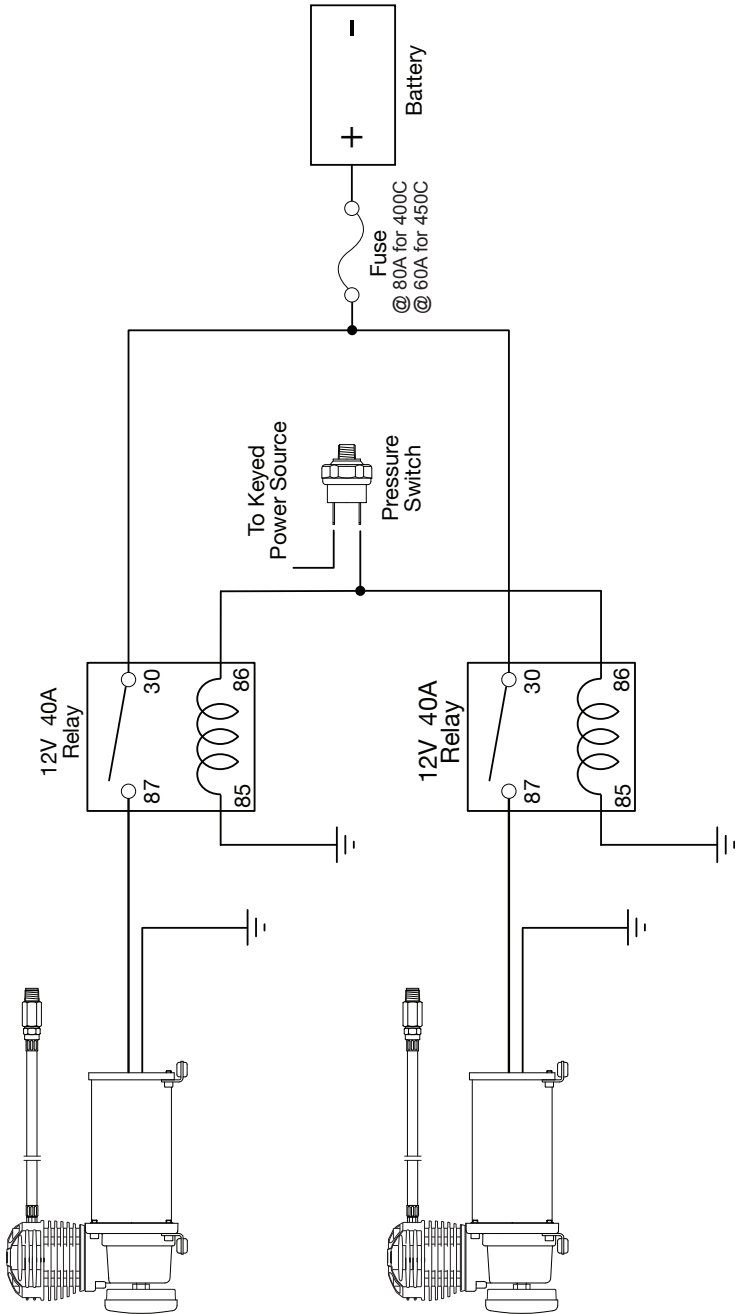

# DUAL 444 EF HIGH PERFORMANCE COMPRESSORS

## SPECIFICATIONS

---

- Part No. 444DB-EF / DUAL 444 High Performance Compressors / Stealth Black (CE Certified)
- Part No. 444DC-EF / DUAL 444 High Performance Compressors / Chrome (CE Certified)

Motor Voltage:	12-Volts
Max. - Amperage - Single:	27-Amps
Max. - Amperage - Combined:	54-Amps
Motor Type:	Permanent Magnetic
Horsepower:	1/4
Max. Working Pressure:	200 PSI*
Max. Duty Cycle (@ 72°F & 100 PSI):	100%
Max. Duty Cycle (@ 72°F & 40 PSI):	50%
Minutes On/Off (@ 72°F & 100 PSI):	Continuous
Minutes On/Off (@ 72°F & 200 PSI):	30 min. / 30 min.
Max. Restart Pressure:	200 PSI
Max. Ambient Temperature:	158°F
Min. Ambient Temperature:	40°F
Auto. Reset Thermal Protection:	Yes
Ingress Protection Rating:	IP67

\* Do not exceed compressor's max working pressure to prevent damage to the compressor.

### LIMITED WARRANTY:

VIAIR® Corporation warrants this product, when properly installed and under normal conditions of use, to be free from defects in workmanship and materials for a period of one year from its original date of purchase. To receive warranty service or repair, please contact VIAIR® Corporation.

Returns should be made within one year of the date of purchase, after a Return Goods Authorization (RGA) number has been assigned by VIAIR® Corporation. To obtain RGA, fax a copy of your receipt to (949) 585-0188. For complete warranty details, please visit: [www.viaircorp.com/warranty](http://www.viaircorp.com/warranty)

### PLEASE NOTE:

THIS WARRANTY COVERS PRODUCT DEFECTS ONLY; IT DOES NOT COVER INCIDENTAL OR CONSEQUENTIAL DAMAGES AS RESULT OF MISUSE OR ABUSE.

This Manual is proprietary to VIAIR® Corporation and no ownership rights are hereby transferred. No part of the Manual shall be used, reproduced, translated, converted, adapted, stored in a retrieval system, communicated or transmitted by any means, for any commercial purpose, including without limitation, sale, resale, license, rental or lease, without the prior express written consent of VIAIR®. VIAIR® does not make any representations, warranties or guarantees, express or implied, as to the accuracy or completeness of the Manual. Users must be aware that updates and amendments will be made from time to time to the Manual. It is the user's responsibility to determine whether there have been any such updates or amendments. Neither VIAIR® nor any of its directors, officers, employees or agents shall be liable in contract, tort or in any other manner whatsoever to any person for any loss, damage, injury, liability, cost or expense of any nature, including without limitation incidental, special, direct or consequential damages arising out of or in connection with the use of the Manual.



15 EDELMAN • IRVINE, CA 92618  
TEL: (949) 585-0011 • FAX: (949) 585-0188  
[www.viaircorp.com](http://www.viaircorp.com)

**USER MANUAL**